



Date: **May 12, 2025**
Project: **Kwethluk Engine-Generator Assembly**
Solicitation No.: **RFQ 25049**
Addendum No.: **01**

TO ALL PLAN HOLDERS:

The following changes, additions, clarifications, and/or deletions are hereby made a part of the RFQ Documents for the above noted project, fully and completely as if the same were fully contained therein. All other terms, conditions, and specifications of the original Request for Proposal, remain unchanged.

This addendum must be acknowledged by email.

The modifications directed by this Addendum One are described on this page and the following attachments:

CHANGES TO DOCUMENTS:

The RFQ Package is hereby clarified, changed, or modified by the following:

The RFQ Due date is hereby changed to May 19, 2025 at 2 PM AKST.

END OF ADDENDUM #01



PROCUREMENT DEPARTMENT
813 W Northern Lights Blvd
Anchorage, AK 99503

RETURN BY EMAIL
AEAProcurement@akenergyauthority.org

REQUEST FOR QUOTATION

RFQ NO: **25049**
Quotations due on/before
2:00 PM Local Time
~~05/14/2025~~
5/19/2025

Engine Generator Assembly

Page 1 of 4 Date: 04/30/25

VENDOR NOTICE (This is NOT a Purchase Order)

This is an **informal quotation** that will not be read at public opening. The information may be publicly reviewed after award. The terms and conditions should be reviewed and understood before preparing a quotation. The quotation shall be the best net price, FOB destination, to include all delivery charges, but exclude applicable taxes. Delivery schedule shall be indicated in the spaces provided below. Please return the quotation by the above time and date to the address: AEAProcurement@akenergyauthority.org. Please reference the RFQ number on the SUBJECT of the email. Please include the completed and signed Debarment Certificate, page 4 of Appendix B.

DELIVERY LOCATION:
Alaska Energy Authority
2601 Commercial Drive
Anchorage AK 99501

PROCUREMENT OFFICER:
Selwin C. Ray (907) 771-3035
AEAProcurement@akenergyauthority.org

VENDOR QUOTATION

Item	Description of Supply or Service	Qty	Unit	Unit Price	Extended Price
1	Fabricated engine-generator assembly with skid, equipment, devices, instrumentation, wiring, loose ship accessories, etc. as indicated in the specifications. Notes: 1) The engine and the generator will be Owner Furnished, see specifications. 2) The scope of work includes submittals, limited testing, and packaging, see specifications.	1	EA		

See the following pages for Standard Terms and Conditions.
See Appendix A Specifications for detailed description of equipment and scope of work.

THIS SECTION MUST BE COMPLETED BY VENDOR

Delivery is desired no later than **July 25, 2025**.
Delivery shall be made by the following date _____.
Note that the schedule for the project is critical to catch a barge so a delivery date significantly later than the desired date may cause a bid to be declared not responsive unless no quotes can meet the desired delivery date.

Company Name	Address	City	St	ZIP Code	Phone Number
Alaska Business License No.	Vendor Tax I.D.				
Signature _____		Date _____		Typed Name and Title _____	

02-110 (03/13)

Revision #1 extends the due date to Monday May 19, 2025.
All other terms and conditions remain unchanged.

**INSTRUCTIONS TO BIDDERS
TERMS AND CONDITIONS**

1. REQUEST FOR QUOTATION (RFQ) REVIEW: Offerors shall carefully review this RFQ for defects and questionable or objectionable material. Offerors' comments concerning defects and questionable or objectionable material in the RFQ must be made in writing and received by the purchasing authority before the date and time set for receipt of quotes. This will allow time for an amendment to be issued if one is required. It will also help prevent the opening of a defective quote, upon which award cannot be made, and the resultant exposure of offerors' prices. Offerors' original comments should be sent to the purchasing authority listed on the front of this RFQ.

2. QUOTATION FORMS: Offerors shall use this and attached forms in submitting quotes. A photocopied quote may be submitted.

3. SUBMISSION: Quotations shall be signed where applicable and received at the designated Purchasing Office no later than as indicated.

4. QUOTE REJECTION: The State reserves the right to reject any or all quotes, combinations of items, or lot(s), and to waive defects or minor informalities.

5. EXTENSION OF PRICES: In case of error in the extension of prices in the quote, the unit prices will govern; in a lot bid, the lot prices will govern. Negligence by the vendor in preparing the quotation confers no right for the withdrawal of the quotation after it has been opened.

6. ALASKA PROCUREMENT CODE: 3 AAC 109 and 2 AAC Ch. 12 are made a part of this document as if fully set forth herein. Note that 3 AAC 109 and 2 AAC Ch. 12 are available at most public libraries and legislative information offices; and both are available for review at Alaska State Purchasing Offices.

7. PRICES: The offeror shall state prices in the units of issue on this RFQ. Prices quoted for commodities must be in U.S. funds and include applicable federal duty, brokerage fees, packaging, and transportation cost to the FOB point so that upon transfer of title the commodity can be utilized without further cost. Prices quoted for services must be quoted in U.S. funds and include applicable federal duty, brokerage fee, packaging, and transportation cost so that the services can be provided without further cost. Prices quoted must be exclusive of federal, state, and local taxes. If the offeror believes that certain taxes are payable by the State, the offeror may list such taxes separately, directly below the bid price for the affected item. The State is exempt from Federal Excise Tax except the following:

- Coal - Internal Revenue Code of 1986 (IRC), Section 4121 - on the purchase of coal;
- "Gas Guzzler" - IRC, Section 4064 - on the purchase of low m.p.g. automobiles, except that police and other emergency type vehicles are not subject to the tax;
- Air Cargo - IRC, Section 4271 - on the purchase of property transportation services by air;
- Air Passenger - IRC, Section 4261 - on the purchase of passenger transportation services by air carriers;
- Leaking Underground Storage Tank Trust Fund Tax (LUST) - IRC, Section 4081 - on the purchase of Aviation gasoline, Diesel Fuel, Gasoline, and Kerosene.

8. PAYMENT FOR STATE PURCHASES: Payment for agreements under \$500,000 for the undisputed purchase of goods or services provided to a State agency, will be made within 30 days of the receipt of a proper billing or the delivery of the goods or services to the location(s) specified in the agreement, whichever is later. A late payment is subject to 1.5% interest per month on the unpaid balance. Interest will not be paid if there is a dispute or if there is an agreement which establishes a lower interest rate or precludes the charging of interest.

9. PAYMENT DISCOUNT: Discounts for prompt payment will not be considered in evaluating the price you quote. However, the State shall be entitled to take advantage of any payment discount(s) offered by the vendor provided payment is made within the discount period. Payment discount periods will be computed from the date of receipt of the commodities or services and/or a correct invoice, whichever is later. Unless freight and other charges are itemized, any discount provided will be taken on full amount of invoice.

10. VENDOR TAX ID NUMBER: If goods or services procured through this RFQ are of a type that is required to be included on a Miscellaneous Tax Statement, as described in the Internal Revenue Code, a valid tax identification number must be provided to the State of Alaska before payment will be made.

11. INDEMNIFICATION: The Contractor shall indemnify, hold harmless, and defend the contracting agency from and against any claim of, or liability for error, omission or negligent act of the Contractor under this agreement. The Contractor shall not be required to indemnify the contracting agency for a claim of, or liability for, the independent negligence of the contracting agency. If there is a claim of, or liability for, the joint negligent error or omission of the Contractor and the independent negligence of the Contracting agency, the indemnification and hold harmless obligation shall be apportioned on a comparative fault basis. "Contractor" and "Contracting agency", as used within this and the following article, include the employees, agents and other contractors who are directly responsible, respectively, to each. The term "independent negligence" is negligence other than in the Contracting agency's selection, administration, monitoring, or controlling of the Contractor and in approving or accepting the Contractor's work.

12. SEVERABILITY: If any provision of this contract is declared by a court to be illegal or in conflict with any law, the validity of the remaining terms and provisions shall not be affected; and the rights and obligations of the parties shall be construed and enforced as if the contract did not contain the particular provision held to be invalid.

13. TITLE: Title passes to the State for each item at FOB destination.

14. FILING A PROTEST: An offeror shall attempt to informally resolve a dispute with the procurement officer regarding a small procurement. If the attempt is unsuccessful, the vendor may protest the solicitation or the award of a small procurement contract under 3 AAC 109 and 2 AAC 02-110 (010/14)

**INSTRUCTIONS TO BIDDERS
TERMS AND CONDITIONS**

Ch. 12. The protest must be filed in writing with the commissioner of the purchasing agency or the commissioner's designee and include the following information: (1) the name, address, and telephone number of the protester; (2) the signature of the protester or the protester's representative; (3) identification of the contracting agency and the solicitation or contract at issue; (4) a detailed statement of the legal and factual grounds of the protest, including copies of relevant documents; and (5) the form of relief requested. The protester must file a copy of the protest with the procurement officer for the purchasing agency. Protests will be treated in accordance with 3 AAC 109 and 2 AAC Ch. 12.

15. COMPLIANCE: In the performance of a contract that results from this RFQ, the contractor must comply with all applicable federal, state, and borough regulations, codes, and laws; and be liable for all required insurance, licenses, permits and bonds; and pay all applicable federal, state, and borough taxes.

16. SUITABLE MATERIALS, ETC.: Unless otherwise specified, all materials, supplies or equipment offered by an offeror shall be new, unused, and of the latest edition, version, model or crop and of recent manufacture.

17. SPECIFICATIONS: Unless otherwise specified in the RFQ, product brand names or model numbers are examples of the type and quality of product required, and are not statements of preference. If the specifications describing an item conflict with a brand name or model number describing the item, the specifications govern. Reference to brand name or number does not preclude an offer of a comparable or better product, if full specifications and descriptive literature are provided for the product. Failure to provide such specifications and descriptive literature may be cause for rejection of the offer.

18. FIRM OFFER: For the purpose of award, offers made in accordance with this RFQ must be good and firm for a period of ninety (90) days from the date of quote opening.

19. QUOTE PREPARATION COSTS: The State is not liable for any costs incurred by the offeror in quote preparation.

20. CONSOLIDATION OF AWARDS: Due to high administrative costs associated with processing of purchase orders, a single low quote of \$50 or less may, at the discretion of the State, be awarded to the next low offeror receiving other awards for consolidation purposes. This paragraph is not subject to the protest terms enumerated in "FILING A PROTEST" above.

21. CONTRACT FUNDING: Offerors are advised that funds are available for the initial purchase and/or the first term of the contract. Payment and performance obligations for succeeding purchases and/or additional terms of the contract are subject to the availability and appropriation of funds.

22. CONFLICT OF INTEREST: An officer or employee of the State of Alaska may not seek to acquire, be a party to, or possess a financial interest in, this contract if (1) the officer or employee is an employee of the administrative unit that supervises the award of this contract; or (2) the officer or employee has the power to take or withhold official action so as to affect the award or execution of the contract.

23. ASSIGNMENT(S): Assignment of rights, duties, or payments under a contract resulting from this RFQ is not permitted unless authorized in writing by the procurement officer of the contracting agency. Quotes that are conditioned upon the State's approval of an assignment will be rejected as nonresponsive.

24. SUBCONTRACTOR(S): Within five (5) working days of notice from the state, the apparent low bidder must submit a list of the subcontractors that will be used in the performance of the contract. The list must include the name of each subcontractor and the location of the place of business for each subcontractor and evidence of each subcontractor's valid Alaska business license.

25. FORCE MAJEURE (Impossibility to perform): The parties to a contract resulting from this RFQ are not liable for the consequences of any failure to perform, or default in performing, any of its obligations under the contract, if that failure or default is caused by any unforeseeable Force Majeure, beyond the control of, and without the fault or negligence of, the respective party. For the purposes of this Agreement, Force Majeure will mean war (whether declared or not); revolution; invasion; insurrection; riot; civil commotion; sabotage; military or usurped power; lightning; explosion; fire; storm; drought; flood; earthquake; epidemic; quarantine; strikes; acts or restraints of governmental authorities affecting the project or directly or indirectly prohibiting or restricting the furnishing or use of materials or labor required; inability to secure materials, machinery, equipment or labor because of priority, allocation or other regulations of any governmental authorities.

26. LATE QUOTES: Late quotes are quotes received after the time and date set for receipt of the quotes. Late quotes will not be accepted.

27. CONTRACT EXTENSION: Unless otherwise provided in this RFQ, the State and the successful offeror/contractor agree: (1) that any holding over of the contract excluding any exercised renewal options, will be considered as a month-to-month extension, and all other terms and conditions shall remain in full force and effect and (2) to provide written notice to the other party of the intent to cancel such month-to-month extension at least thirty (30) days before the desired date of cancellation.

28. DEFAULT: In case of default by the contractor, for any reason whatsoever, the State of Alaska may procure the goods or services from another source and hold the contractor responsible for any resulting excess cost and may seek other remedies under law or equity.

29. DISPUTES: If a contractor has a claim arising in connection with a contract resulting from this RFQ that it cannot resolve with the State by mutual agreement, it shall pursue a claim, if at all, in accordance with the provisions of 3 AAC 109 and 2 AAC Ch. 12.

**INSTRUCTIONS TO BIDDERS
TERMS AND CONDITIONS**

30. GOVERNING LAW; FORUM SELECTION: A contract resulting from this RFQ is governed by the laws of the State of Alaska. To the extent not otherwise governed by section 29 of these Standard Terms and Conditions, any claim concerning the contract shall be brought only in the Superior Court of the State of Alaska and not elsewhere.

31. CONSUMER ELECTRICAL PRODUCT: AS 45.45.910 requires that "...a person may not sell, offer to sell, or otherwise transfer in the course of the person's business a consumer electrical product that is manufactured after August 14, 1990, unless the product is clearly marked as being listed by an approved third party certification program." Electrical consumer products manufactured before August 14, 1990, must either be clearly marked as being third party certified or be marked with a warning label that complies with AS 45.45.910(e). Even exempted electrical products must be marked with the warning label. By signature on this quote the offeror certifies that the product offered is in compliance with the law. A list of approved third party certifiers, warning labels and additional information is available from: Department of Labor, Labor Standards & Safety Division, Mechanical Inspection Section, P.O. Box 107020, Anchorage, Alaska 99510-7020, (907)269-4925.

32. CONTINUING OBLIGATION OF CONTRACTOR: Notwithstanding the expiration date of a contract resulting from this RFQ, the contractor is obligated to fulfill its responsibilities until warranty, guarantee, maintenance and parts availability requirements have completely expired.

33. ORDER DOCUMENTS: Except as specifically allowed under this RFQ, an ordering agency will not sign any vendor contract. The State is not bound by a vendor contract signed by a person who is not specifically authorized to sign for the State under this RFQ. The State of Alaska Purchase Order, Contract Award and Delivery Order are the only order documents that may be used to place orders against the contract(s) resulting from this RFQ.

34. BILLING INSTRUCTIONS: Invoices must be billed to the ordering agency's address shown on the individual Purchase Order, Contract Award or Delivery Order. The ordering agency will make payment after it receives the merchandise or service and the invoice. Questions concerning payment must be addressed to the ordering agency.

35. OFFERORS WITH DISABILITIES: The State of Alaska complies with Title II of the Americans with Disabilities Act of 1990. Individuals with disabilities who may need auxiliary aids, services, and/or special modifications to participate in this procurement should contact the procurement officer named on the cover page of this RFQ as soon as possible, but no later than the date and time quotations are due to make any necessary arrangements.

36. COMPLIANCE WITH ADA: By signature of their quote the bidder certifies that they comply with the Americans with Disabilities Act of 1990 and the regulations issued thereunder by the federal government. Services or activities furnished to the general public on behalf of the State must be fully accessible. This is intended to ensure that agencies are in accordance with 28 CFR Part 35 Section 35.130 and that services, programs or activities furnished to the public through a contract do not subject qualified individuals with a disability to discrimination based on the disability.

37. FEDERAL ASSURANCES: Because this contract is funded with federal funds, the provisions of Appendix B, Federal Assurances, shall apply. When submitting the quote, the vendor shall include the Debarment Certificate, page 4 of Appendix B.

SECTION 26 32 13.50
ENGINE GENERATOR ASSEMBLY

PART 1 - GENERAL

1.1 SCOPE

- A. Receive Owner Furnished engine and generator.
- B. Provide skid base, supports, fasteners, hardware, hoses, devices, wiring, etc.
- C. Assemble into a complete engine-generator package that is ready for field installation.
- D. Provide engine wiring j-box with voltage regulator, devices, wiring, etc. Provide wiring harnesses for interconnection with engine and generator. Power up j-box and verify engine ECU and verify proper function of all circuits.
- E. Provide all loose ship accessories as specified.

1.2 RELATED REQUIREMENTS – not used

1.3 SUBMITTALS

Provide submittals in Adobe Acrobat PDF format. Note that a maximum of three separate submittals may be provided in accordance with the categories listed below.

- A. Catalog Literature: Provide manufacturer's data sheets for air cleaner, guard, instrumentation, hoses, conductors, and all other items specified herein.
- B. Fabrications: Provide shop drawings for the skid and other fabricated drawings. Note that if all items will be fabricated exactly as indicated on the Drawings, the design Drawings can be submitted in lieu of shop drawings.
- C. Control Wiring Junction Box: Provide shop drawings for the junction box and manufacturer's data sheets for all equipment being installed in the junction box.

1.4 REGULATORY COMPLIANCE – not used

1.5 QUALITY ASSURANCE

- A. Equipment and components furnished under these specifications shall be of new manufacture or factory remanufactured and be meet OEM requirements.

1.6 FABRICATOR QUALIFICATIONS

- D. The engine generator shall be assembled and tested by a qualified fabricator (Fabricator) who is regularly engaged in the business of providing diesel engine driven generator equipment.
- E. The Fabricator must have staff with extensive experience in packaging diesel engine driven electrical generators. A list of five successful installations that key staff have worked on may be requested by the Authority after the bid opening and prior to award in order to verify Fabricator qualifications. The list must include installation date, description of installation, and a reference contact for each installation.

1.7 FABRICATOR WARRANTIES – not used

1.8 OPERATION AND MAINTENANCE MANUALS – not used

PART 2 - PRODUCTS

2.1 GENERAL CONFIGURATION OF ENGINE AND GENERATOR

The engine generator shall be shop assembled from Owner Furnished and Fabricator Furnished components. The configuration shall be as specified herein and indicated in the attached Drawings.

2.2 OWNER FURNISHED ENGINE AND GENERATOR MANUFACTURER/MODEL

Engine - 764 HP at 1800 rpm, 450ekW prime power. Caterpillar, 15.8 liter, Model 3456, Serial Number 9BZ00446.

Generator – Newage/Stamford HCI534E with PMG.

2.3 OWNER FURNISHED ENGINE CONFIGURATION

A. The Owner Furnished engine is a low hour old stock engine. The engine has passed an eight hour dyno test and has been determined to suitable for prime power operation. The following modifications will be made to the engine prior to delivery:

1. The military gear train replacement has been completed.
2. Custom angled coolant connection fittings with 3” barbed king nipples and a 1/2" threaded ball valve vent/pre-heat connection have been installed.
3. A deep sump oil pan for 500 hour service has been installed. The lubricating oil has been drained.
4. The engine has been painted Caterpillar Yellow.
5. The ECM has been flashed for 450ekW prime power low BSFC.

2.4 ENGINE CONTROL AND MONITORING

- A. The engine is configured for 24VDC control and starting.
- B. Engine Control: The engine is equipped with an ADEM ECM, all sensors, and complete OEM harnesses.

2.5 ENGINE MOUNTED ACCESSORIES, WIRING, AND PIPING

- A. Fuel and Oil Hoses: All hoses for fuel, lube oil, vents, mechanical gauges, etc., shall be Aeroquip type FC300, Eaton Weatherhead H569 or approved equal. Minimum hose size shall be 5/16” (#6). Provide with re-useable JIC swivel type fittings. Push-on or barb type hose connections will not be allowed. Route hoses to avoid wear points and to ensure access to normal service points on the engine. Securely support hoses from engine and skid.
- B. Glycol Hoses: All hoses for glycol shall be Teflon hose with stainless steel outer braid, Eaton Weatherhead H243 or approved equal. Provide with re-useable plated steel straight JIC swivel ends with NPT adapters. Route hoses to avoid wear points and to ensure access to normal service points on the engine. Securely support hoses from engine and skid.

- C. Wire Loom: All wiring for control and instrumentation shall be routed in plastic loom. Provide tee fittings for all branch connections. Route loom to avoid wear points and to ensure access to normal service points on the engine. Securely support loom from engine and skid.
- D. Protective Guards: Furnish a Caterpillar Part Number 352-9719 damper guard and install as indicated on the Drawings. Furnish loose ship two complete damper guard assemblies including mounting brackets, isolators, and fasteners for field installation by others on existing engines.
- E. Air Cleaner: Furnish a Caterpillar Group Part Number 151-7736 air cleaner and install as indicated on the Drawings. Note that the utility has an extensive stock of replacement elements so substitute air cleaners will not be accepted.
- F. Air Restriction Indicator: Provide visual air restriction indicator, 1/8" MPT, 20" water column limit, manual reset, Donaldson X002251 or approved equal. Install in air filter cannister or in FPT fitting in piping from the air cleaner to the turbocharger inlet.
- G. Crankcase Ventilation Adapter: Provide a fumes disposal adapter, Caterpillar Group Part Number 223-9784, complete with clamps and hardware for connection to engine.
- H. Fuel Piping Termination: Fuel supply and return lines shall be routed to the front of generator skid for field connection to the plant piping. See Drawings for detailed configuration.
- I. Lube Oil Piping Termination: The oil drain line shall be routed to the front of generator skid for field connection to the plant piping. See Drawings for detailed configuration.
- J. Oil Level: The engine shall have a combination visual oil level site gauge with adjustable high and low level switches, Murphy L129CK1 or approved equal. Mount on rubber isolators and connect to engine with minimum #8 hoses. Carefully route upper vent hose to create a high point and connect directly into crankcase. Route lower hose to a connection directly on the oil pan. Do not tee lower hose into oil drain line. See Drawings for detail. Note the following:
 - 1. The engine oil was previously drained during installation of the deep sump oil pan.
 - 2. Provide minimum 24" long hoses as indicated to allow flexibility in field positioning. Install JIC by NPT adapters and threaded caps and coil hoses for shipping.
- K. Provide an oil pressure sensor, Murphy Model ES2P-100-1/8, mounted through the bottom of the new engine control wiring j-box enclosure as indicated on the Drawings. Route #6 oil hose from the sensor to a port on the engine block on the high pressure oil supply.
- L. Provide two each #2/0 AWG arctic flex battery cables, length as required to extend 6' minimum beyond the front of the skid. Both cables shall include compression type terminal ends shipped loose. One battery cable shall be red for the positive

lead and the other shall be black for the negative lead. The battery cables shall be routed and supported as indicated on the Drawings.

- M. Engine Shop Mounted Device Wiring: Furnish and install new devices for monitoring engine functions. Route wires on the engine-generator within the wiring loom and connect to the engine wiring j-box. See Drawings for termination details. Provide the following devices:
1. Magnetic Pickup: Davidson Sales Co. Model DSC15400 mag pickup and Model DSC010 wiring harness or approved equal.
 2. Engine Water Temperature Sensor: Murphy Model ES2T-250/300-1/2 or approved equal.
- N. Engine Field Mounted Device Wiring: During field installation, existing instrumentation devices that are on site will be installed and connected to the engine wiring j-box. See Drawings for termination details. As part of the shop assembly, route wires on the engine-generator within the wiring loom to the approximate locations indicated below and provide minimum 5' long tails for field termination. Following are the devices and locations:
1. Exhaust Gas Temperature Sensor: 100 ohm RTD to be installed in exhaust flex.
 2. Intake Air Temperature Sensor: 4-20mA temperature transmitter to be installed in the charge air return tubing above the left front of the engine .
 3. Air Filter Vacuum Sensor: 4-20mA pressure transmitter to be installed in the shop installed piping from the air cleaner to the turbocharger inlet. Provide a minimum 1/4" FPT fitting in steel tube.
 4. Oil Level Gauge/Switch: The shop fabricated oil level gauge/switch specified previously will be field installed near the right rear of the engine as indicated on the Drawings.

2.6 ENGINE MODIFICATIONS

Not used this specification. Modifications previously completed on Owner Furnished engine.

2.7 COOLING SYSTEM

Not used this specification. Modifications previously completed on Owner Furnished engine.

2.8 EXHAUST FLEX

The Owner Furnished engine will be furnished with an exhaust flex, 4-hole Cat flange by 8" floating flange, with 1/4" FPT port for exhaust temp sensor.

2.9 GENERATOR/ALTERNATOR

- A. Install the new Owner Furnished generator/alternator on the steel skid and connect to the engine. See paragraph 3.1 and Drawings.
- B. Paint the Owner Furnished generator/alternator with machinery enamel, color Caterpillar yellow, to match the Owner Furnished engine.
- C. The Newage standard voltage regulator has been removed and the wiring for 3 phase voltage sensing, field, and PMG have been left loose in the generator terminal

compartment. Furnish and install terminal blocks in the generator and provide wiring to the engine control wiring junction box in ¾" liquid tight flex.

2.10 MOUNTING SKID

- A. Fabricate a full length base frame (skid) for mounting the engine and generator. The skid shall be constructed from structural steel channel with ends beveled and plated for short term skidding and rolling of unit. Provisions shall be made so that the generator can slide back a minimum of 12" to access the rear main seal on the engine without removing the generator end off of the skid or requiring the use of blocking to support it. See the Drawings for skid design and layout.
- B. Provisions shall be made in the skid for the mounting of vibration isolators at locations as indicated on the Drawings. Wedge washers shall be welded in place on the skid to provide a flat surface for the vibration isolator lock nuts.
- C. The engine generator shall be placed on the skid at the location indicated on the Drawings.
- D. Fabricate s structural steel frame for mounting the air cleaner over the top of the generator.
- E. Upon completion of fabrication round all corners and grind all welds and edges smooth. The entire skid, including the air cleaner support frame, shall be cleaned, abraded, and coated with two coats of machinery enamel, color black.

2.11 CONTROL WIRING JUNCTION BOX WITH VOLTAGE REGULATOR

Provide a control wiring junction box. It will be field installed on a strut rack above the left-hand side of the generator enclosure. See Drawings for location and installation. Furnish the junction box with the following features:

- A. NEMA 12 steel enclosure with hinged door and screw down latches. B-Line, Hoffman or approved equal. See Drawings for size.
- B. The junction box orientation, device layout, terminal block layout, and labeling shall be as indicated on the Drawings.
- C. All wiring for control, monitoring, and safety shall be terminated on terminal blocks within the control wiring junction. The terminals shall be IDEC or approved equal, BNH15LW except where indicated 50A provide BNH50W. Terminals shall be mounted on DIN rail with heavy duty end anchors. Each terminal block and all wire terminations shall be individually numbered as indicated.
- D. A voltage regulator shall be provided with the junction box. The voltage regulator shall be the same as the existing voltage regulators on the other generators in the power plant. Cat CDVR model number 314-7755, no substitutes.
 - 1. The voltage regulator shall be configured for rear mounting and shall be mounted inside of the control wiring junction box as indicated in the Drawings.
 - 2. The voltage regulator shall be configured for connection to 3 phase voltage sensing, field, and PMG on terminal blocks in the control wiring junction box as indicated in the Drawings.

- E. Provide complete with all devices listed in the bill of materials on Drawings and with all accessories required for a complete system.

2.12 PAINTING

- A. As previously specified, paint the generator/alternator Caterpillar yellow and paint the skid and air cleaner support black.

2.13 LOOSE SHIP ACCESSORIES

- A. Package the previously specified items loose ship:
 - 1. Oil level gauge/switch with mounting plate and hardware.
 - 2. Owner Furnished exhaust flex.
- B. Provide the following additional items loose ship:
 - 1. Vibration Isolators: Provide four each spring vibration isolators complete with mounting hardware. Caldyn Type RJC 3040 or approved equal.
 - 2. Drip Pan: Provide 1 each drip pan, 16-gauge galvanized sheet metal, liquid tight joints, 28" wide by 78" long by 1" high.
 - 3. Additional Damper Guards: In addition to the damper guard shop installed on the engine-generator, furnish loose ship two complete damper guard assemblies with mounting brackets, isolators, and fasteners.

2.14 SPARE FILTERS

Not required. The utility has an adequate stock of filters.

PART 3 - EXECUTION

3.1 SHOP ASSEMBLY

- A. Prior to beginning assembly, thoroughly inspect engine and generator for manufacturing defects or for damage that may have occurred in shipping. Verify that the shipping arms on the front of the generator are intact and that rotor is properly centered. Check inside of generator for dirt or moisture and clean thoroughly.
- B. Replace the standard factory hardware used for attachment of the generator coupling disc to the engine flywheel with Grade 8 hex head bolts. Install heavy gauge washers, tighten and torque bolts in accordance with manufacturer's specifications, and paint pen mark after final torquing.
- C. Upon assembly of engine and generator on the skid, ensure proper alignment then adjust and secure supports to ensure alignment is maintained.
- D. Route hoses and wiring to avoid wear points and to ensure access to normal service points on the engine. Securely support hoses and wiring from engine and skid.
- E. Make up complete wiring harnesses for all wiring from j-box to engine and to generator with j-box physically located as shown.
- F. Cover all engine wiring with split plastic loom. Install all wiring to generator in 3/4" liquid tight flex.

- G. Install hose from oil pressure sensor in junction box to engine block as previously specified.
- H. Provide approximate 12” service loops in wiring and hose.
- I. At locations for field installed devices route wires on the engine-generator within the wiring loom to the approximate locations indicated and provide minimum 5’ long tails for field termination.

3.2 SHOP TESTS

- A. Power up engine ECM and control wiring j-box. Connect to diagnostic port or harness and using Cat ET software verify proper reading of all engine data.

3.3 PREPARATION AND SHIPPING

- A. Upon completion of testing perform the following steps to prepare for shipping:
 - 1. Wrap j-box with foam rubber and shrink wrap then strap to generator.
 - 2. Fasten wooden dunnage to skid to allow lifting with a forklift.
 - 3. Put a waterproof cover over the entire engine generator. Make the cover tight, but loose enough to let air circulate around the unit to prevent damage to exposed metal parts from condensation.
 - 4. Cover all loose ship items with waterproof wrapping and pack in boxes or crates. Provide packing slips on each box/crate indicating the contents. Shrink wrap all boxes/crates to a single pallet.

END OF WRITTEN SPECIFICATIONS

SEE DRAWINGS M3.6, E3.5, E6.5, AND E6.6 WHICH FOLLOW

1 GEN#3 ENGINE-GENERATOR ASSEMBLY & MODIFICATION
M3.6 3/4"=1'-0"

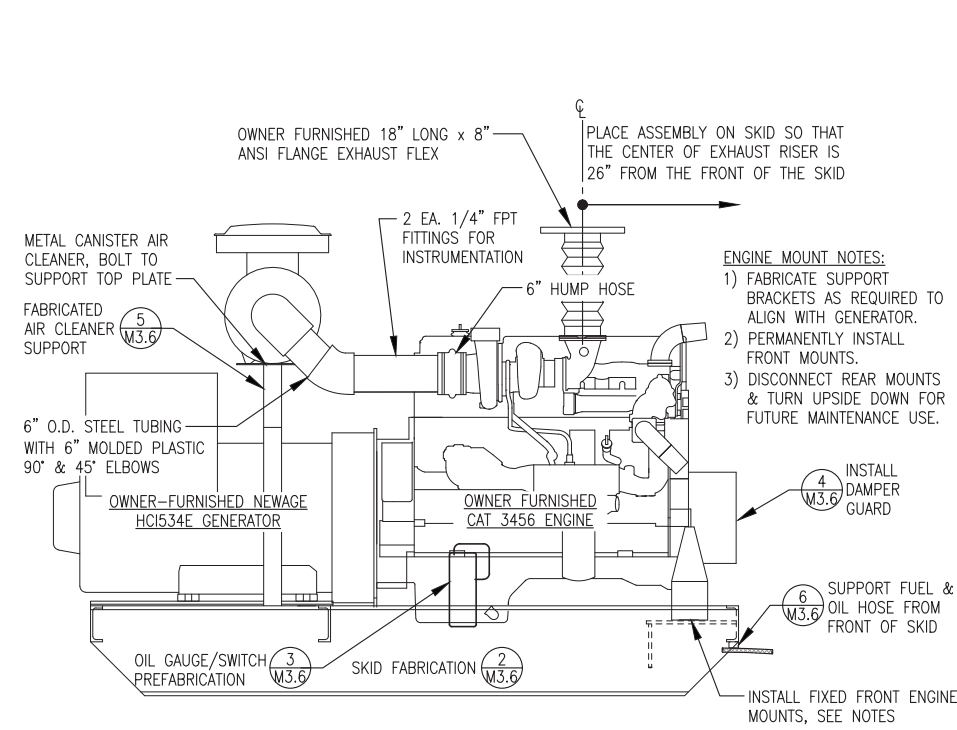

2 GEN#3 SKID FABRICATION
M3.6 NO SCALE

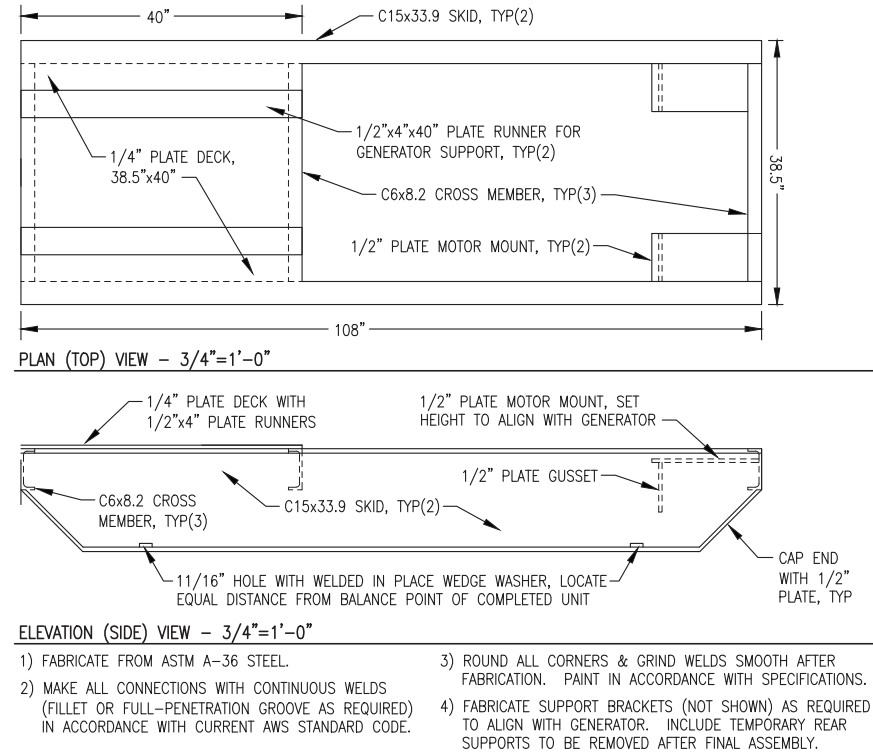

3 OIL LEVEL SITE GAUGE/SWITCH PREFABRICATION
M3.6 NO SCALE

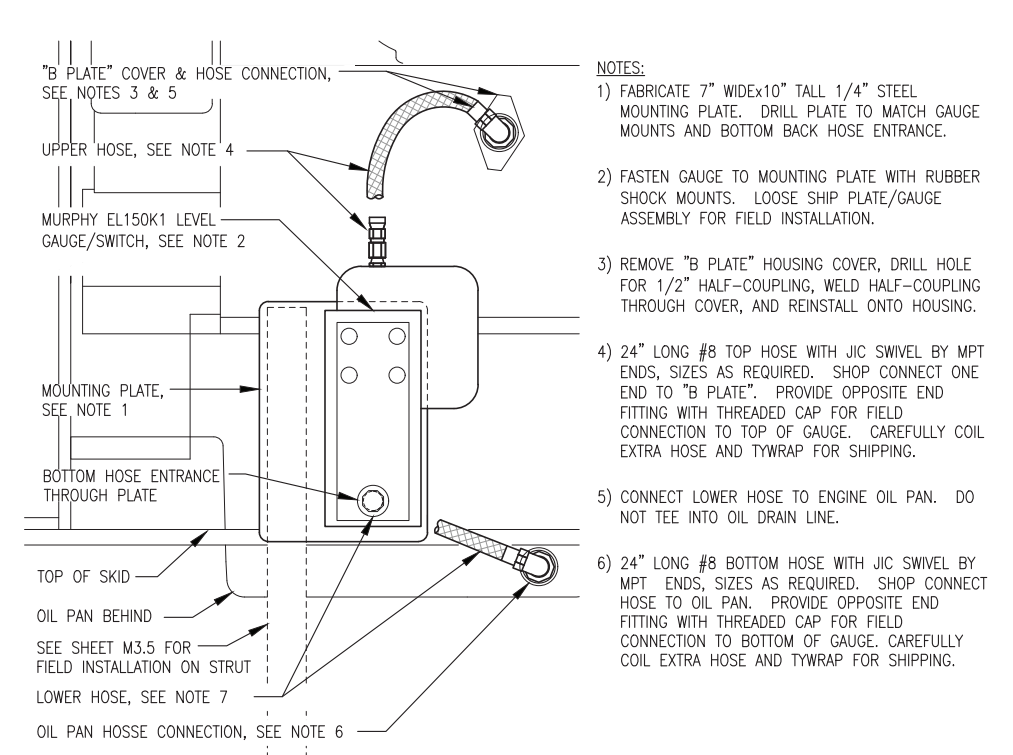

NOTES:
1) FURNISH & INSTALL ONE COMPLETE DAMPER GUARD ASSEMBLY ON NEW GENSET.
2) FURNISH LOOSE SHIP TWO COMPLETE ASSEMBLIES INCLUDING MOUNTING BRACKETS, ISOLATORS, & FASTENERS FOR FIELD INSTALLATION BY OTHERS.

FABRICATE BENT STEEL BRACKET, LENGTH AS REQUIRED TO SECURE DAMPER GUARD TO WATER PUMP HOUSING

PROVIDE RUBBER SPACERS AT ALL MOUNTING LOCATIONS FOR VIBRATION ISOLATION

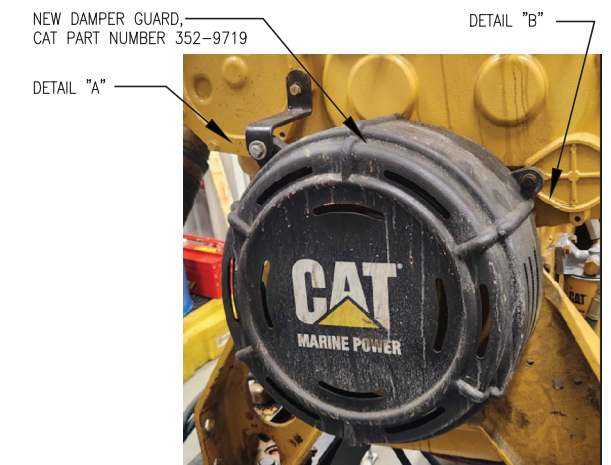
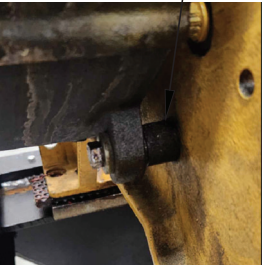
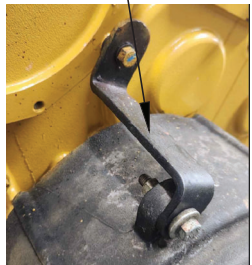

4 DAMPER GUARD INSTALLATION
M3.6 NO SCALE

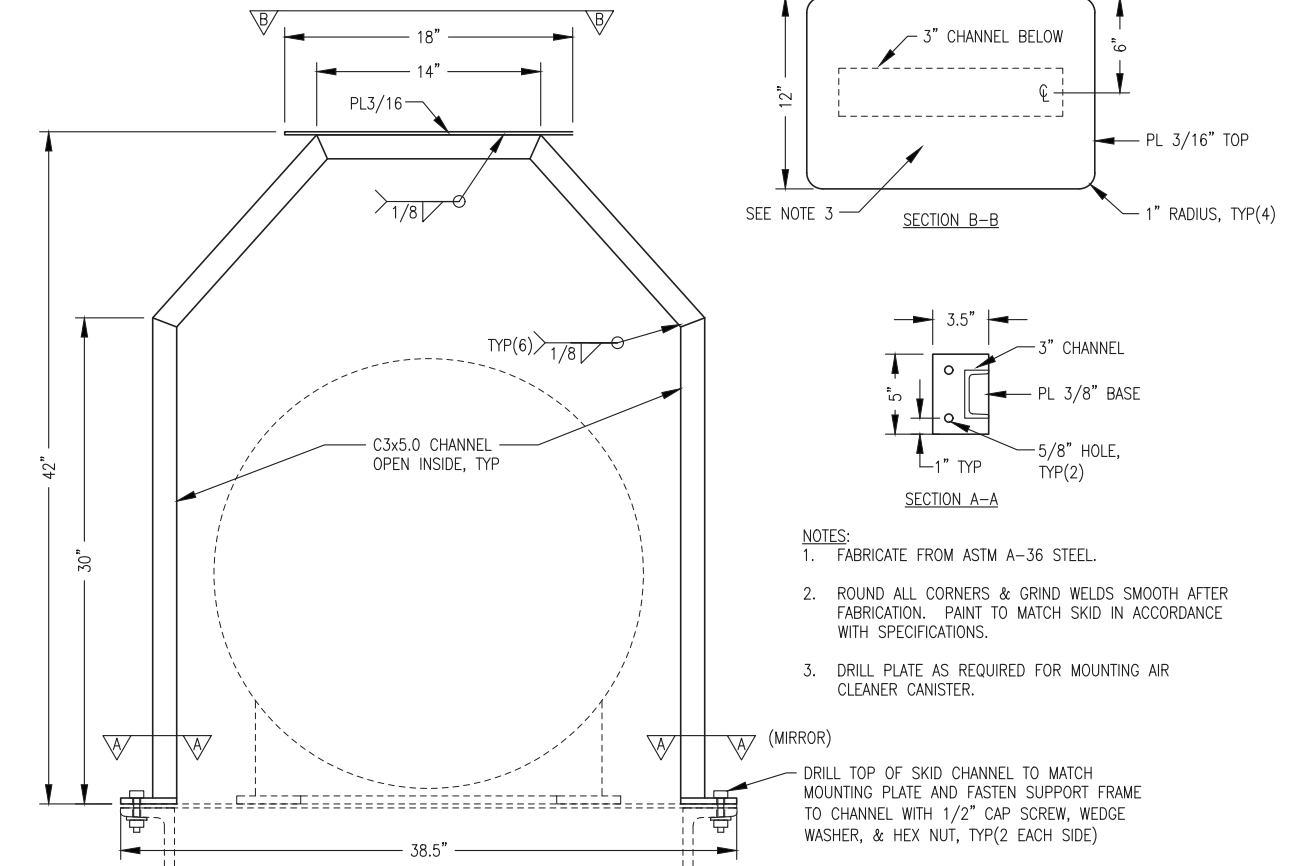

5 AIR CLEANER SUPPORT FABRICATION
M3.6 NO SCALE

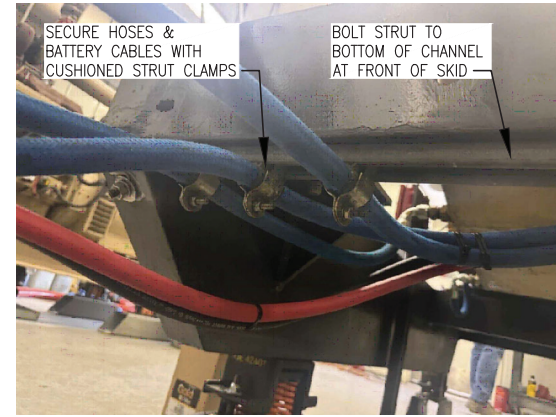

6 FUEL & OIL HOSE SUPPORT
M3.6 NO SCALE

NOTES:
1. FABRICATE FROM ASTM A-36 STEEL.
2. ROUND ALL CORNERS & GRIND WELDS SMOOTH AFTER FABRICATION. PAINT TO MATCH SKID IN ACCORDANCE WITH SPECIFICATIONS.
3. DRILL PLATE AS REQUIRED FOR MOUNTING AIR CLEANER CANISTER.

ISSUED FOR
ENGINE
GENERATOR
PROCUREMENT

ALASKA ENERGY AUTHORITY		
PROJECT: KWETHLUK M&I 2025 IMPROVEMENTS		
TITLE: GEN#3 ENGINE-GENERATOR SHOP ASSEMBLY DETAILS		
	DRAWN BY: JTD DESIGNED BY: BCG FILE NAME: KWT 2025 M&I PROJECT NUMBER:	SCALE: AS NOTED DATE: 4/25/25 SHEET: PROJECT NUMBER: M3.6

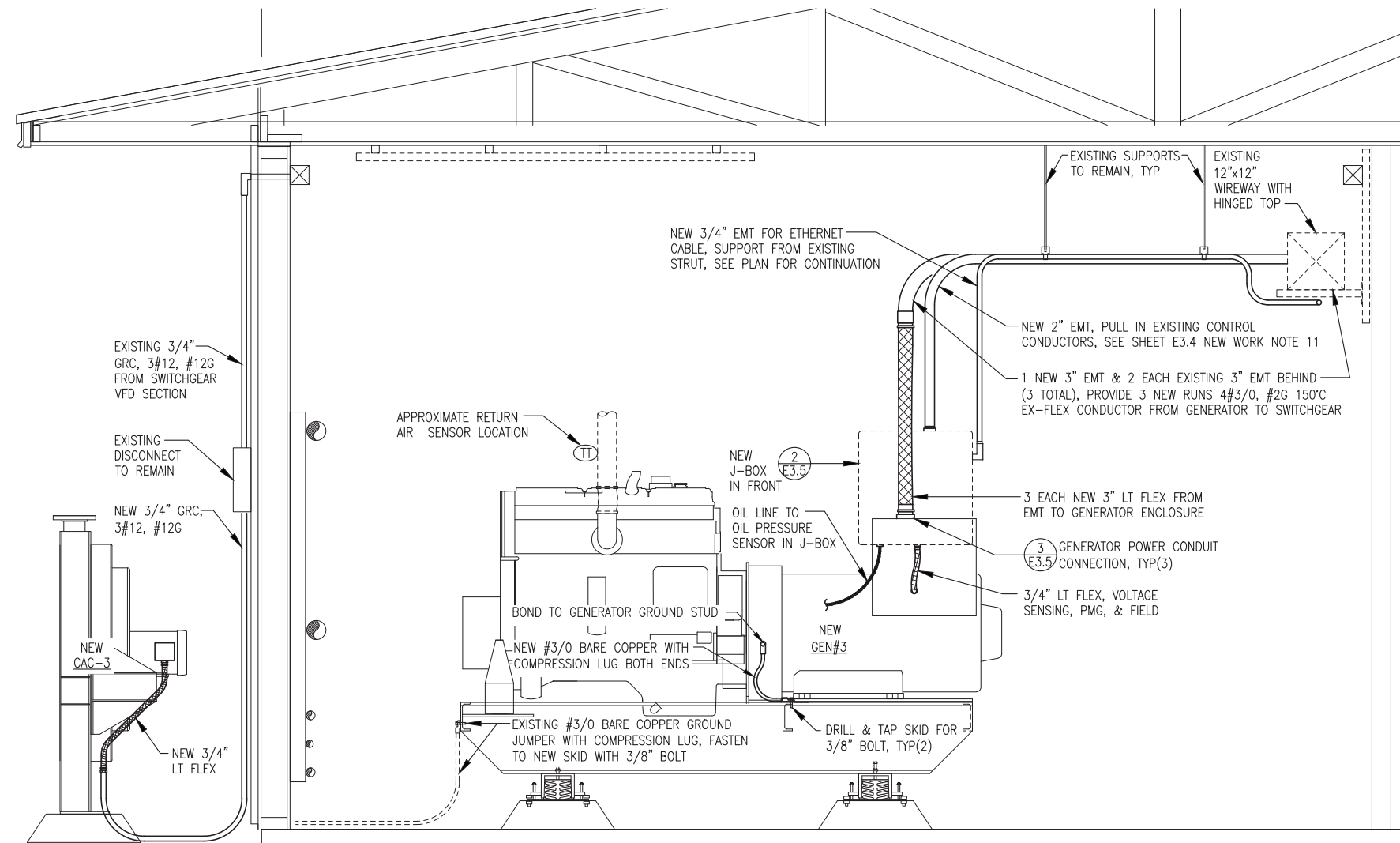

1 NEW GEN#3 INSTALLATION ELEVATION
E3.5 3/4"-1'-0"

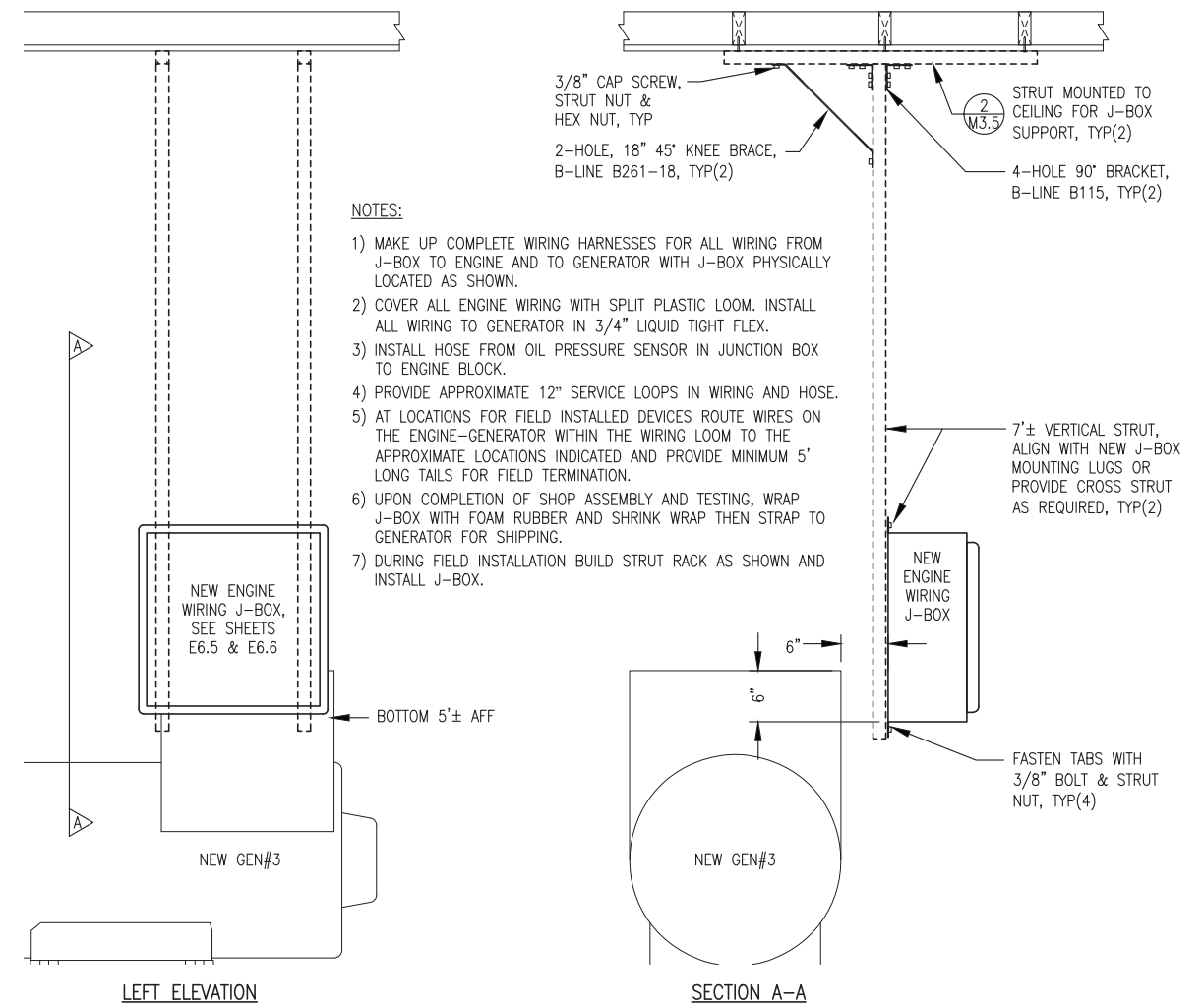

2 NEW ENGINE J-BOX INSTALLATION
E3.5 NO SCALE

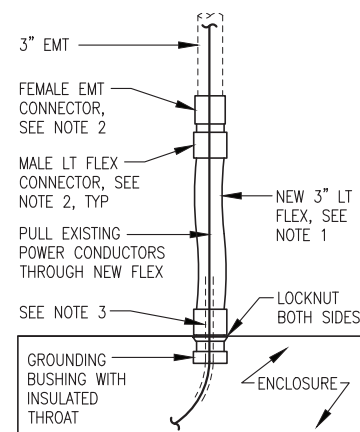

NOTES:

- 1) ONE CONDUIT CONNECTION SHOWN, PROVIDE THREE IDENTICAL.
- 2) THE NEW GENERATOR WILL BE TALLER THAN THE EXISTING SO TWO EXISTING 3" LT FLEX CAN BE SALVAGED AND CUT SHORTER ALONG WITH ONE NEW 3" LT FLEX TO MAKE THREE FINAL CONNECTIONS. IT IS ESTIMATED THAT 30"-36" WILL BE REQUIRED FOR EACH CONNECTION.
- 3) SALVAGE EXISTING FLEX CONNECTORS, EMT CONNECTORS, AND GROUNDING BUSHINGS FROM TWO EXISTING CONNECTIONS DURING DEMOLITION AND REINSTALL WITH NEW AS REQUIRED.
- 4) PROTECT CABLES FROM WEAR BY INSTALLING 1 EACH 12" LONG LAYER OF HEAT SHRINK, CENTERED IN CONNECTOR.

3 GENERATOR POWER CONDUIT CONNECTION
E3.5 NO SCALE

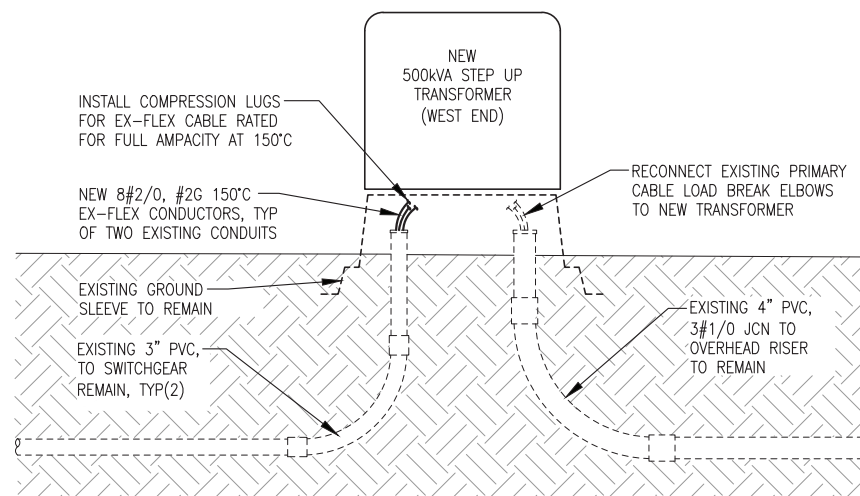

4 NEW 500KVA WEST FEEDER TRANSFORMER INSTALLATION
E3.5 NO SCALE

NOTE: THIS DRAWING SHOWS PRIMARILY FIELD INSTALLATION WORK THAT IS NOT PART OF THE ENGINE-GENERATOR ASSEMBLY SCOPE. IT IS INCLUDED HERE TO PRIMARILY SHOW THE LOCATION OF THE J-BOX.

ISSUED FOR
ENGINE
GENERATOR
PROCUREMENT



PROJECT: KWETHLUK M&I 2025 IMPROVEMENTS	
TITLE: GEN#3 INSTALLATION ELEVATION & DETAILS	
DRAWN BY: JTD	SCALE: AS NOTED
DESIGNED BY: CWV/BCG	DATE: 4/25/25
FILE NAME: KWT 2025 M&I	SHEET:
PROJECT NUMBER:	E3.5



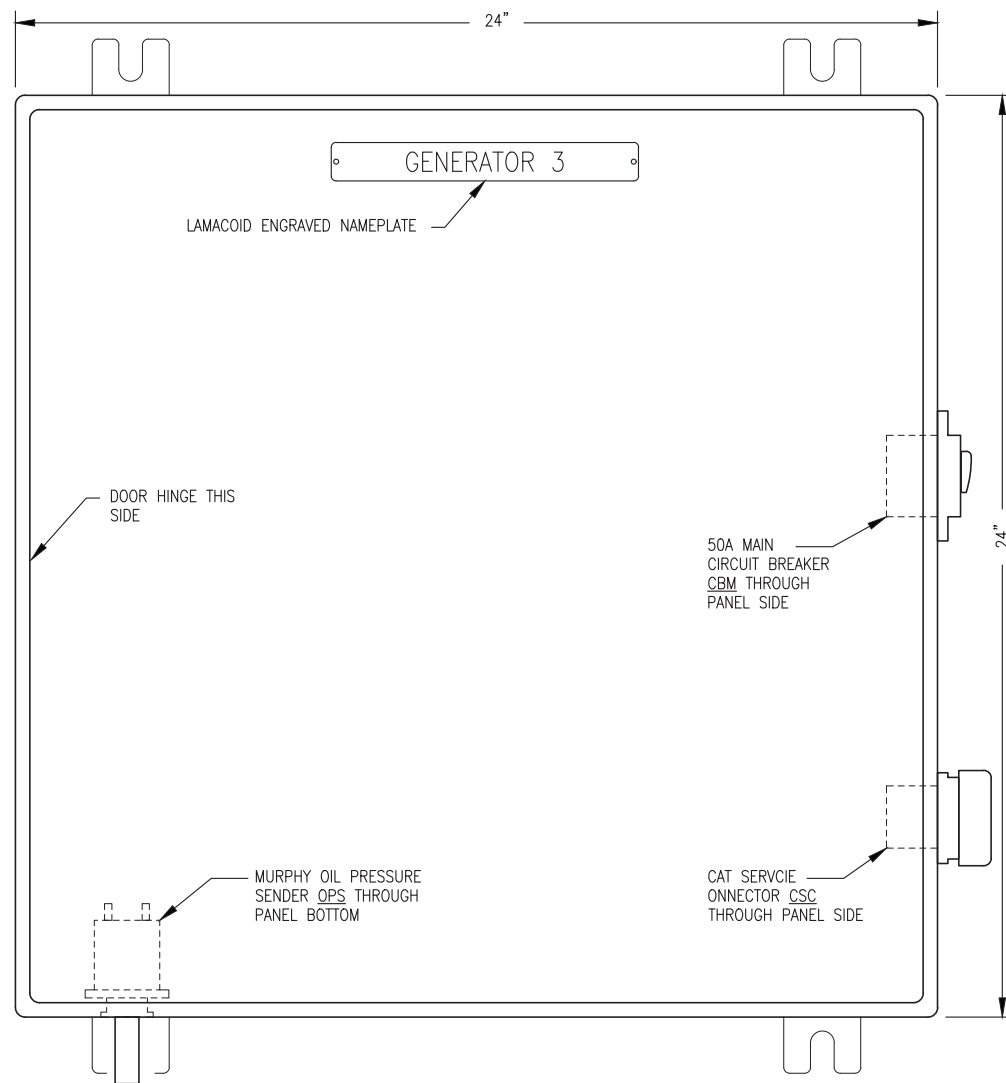

1 JUNCTION BOX FRONT PANEL LAYOUT
E6.5 NO SCALE

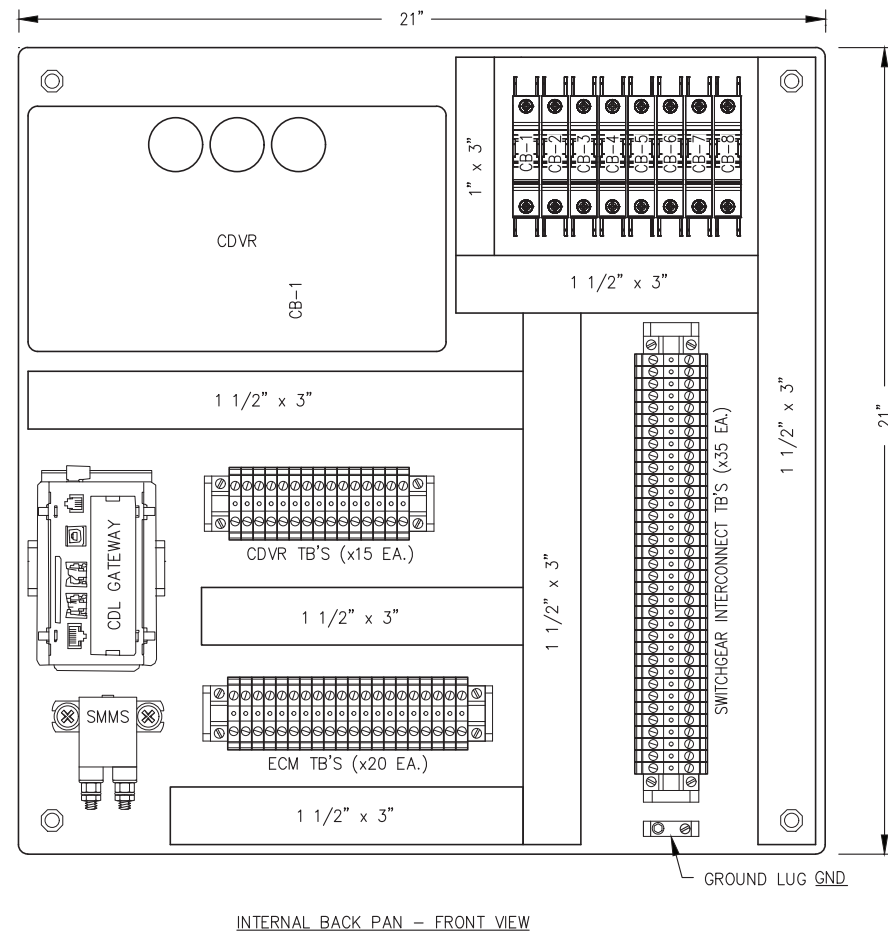

2 JUNCTION BOX SUB PANEL LAYOUT
E6.5 NO SCALE

BILL OF MATERIALS			
TAG	MANUFACTURER	MODEL	DESCRIPTION
CBM	BLUE SEA SYSTEM	CB187P-50	PANEL MOUNT CIRCUIT BREAKER, 1P, 50A
CB-6,7,8	ALLEN-BRADLEY	1489-M1-D010	RAIL MOUNT CIRCUIT BREAKER, 1P, 1A
CB-1,2,3,4,5	ALLEN-BRADLEY	1489-M1-D100	RAIL MOUNT CIRCUIT BREAKER, 1P, 10A
CDL GATEWAY	MONICO	CDL-MCLE-MB-30K	CAT DATA LINK TO MODBUS TCP GATEWAY CABLE
	MONICO	CBL-CDL-7	CABLE
CDVR	CAT	314-7755	CAT DIGITAL VOLTAGE REGULATOR
	CUSTOM	CDVR WIRE HARNESS	
CSC	DEUTSCH	HD10-9-96P-B009	DIAGNOSTIC CONNECTOR, 9-PIN
	DEUTSCH	HD18-009	CONNECTOR STRAIN RELIEF
	DEUTSCH	HDC16-9	CONNECTOR PROTECTIVE DUST CAP
	DEUTSCH	HD10-9-GKT	CONNECTOR GASKET
	DEUTSCH	JDL082397	CONNECTOR LANYARD
	DEUTSCH	0460-215-16141	14 AWG PINS
	DEUTSCH	0460-202-16141	16 AWG PINS
ENCL.	SAGINAW	SCE-24EL2408LP	24x24x8" NEMA 12
	SAGINAW	SCE-24P24	BACK PANEL 21"x21"
	SAGINAW	SCE-ELMFK4	WALL MOUNT KIT
GND	BURNDY	KA2U	GROUNDING LUG
OPS	MURPHY	ES2P-100	OIL PRESSURE SENSOR
SMMS	CAT	9X8124	STARTER AUXILIARY SOLENOID, 24V
TB-1	IDEC	BNH15LW	15A DIN RAIL-MOUNT TERMINAL BLOCK
TB-2	IDEC	BNH50W	50A DIN RAIL-MOUNT TERMINAL BLOCK

BRAND SPECIFIC NOTE: SPECIFIC PARTS MANUFACTURER AND MODEL SELECTED NOT ONLY TO MEET PERFORMANCE FUNCTION BUT ALSO TO COORDINATE AND INTERFACE WITH OTHER DEVICES AND SYSTEMS. APPROVED EQUAL SUBSTITUTIONS WILL BE ALLOWED ONLY BY ENGINEER'S APPROVAL. TO OBTAIN APPROVAL, SUBMITTALS MUST CLEARLY DEMONSTRATE HOW SUBSTITUTE ITEM MEETS OR EXCEEDS SPECIFIED ITEM QUALITY AND PERFORMANCE CHARACTERISTICS AND ALSO COMPLIES WITH MECHANICAL AND/OR ELECTRICAL CONNECTIONS AND PHYSICAL LAYOUT REQUIREMENTS.

- SHOP FABRICATION NOTES:**
- 1) PROVIDE ASSEMBLY WITH ALL DEVICES AND WIRING INDICATED.
 - 2) INSTALL IN A 24"x24"x8" NEMA 12 WALL MOUNT ENCLOSURE WITH MOUNTING FLANGES AT BACK, A MIN 14 GAUGE INTERIOR BACK PANEL AND HINGED LOCKABLE DOOR.
 - 3) PROVIDE DIN RAIL, TERMINAL END PLATES, TERMINAL END STOPS, TERMINAL DUST COVERS AND OTHER MISCELLANEOUS HARDWARE AS REQUIRED TO MATCH TERMINALS. LABEL ALL TERMINALS EXACTLY AS INDICATED ON THE DETAILS.
 - 4) ALL WIRE #14AWG EXCEPT WHERE SPECIFICALLY INDICATED OTHERWISE. LABEL BOTH ENDS OF ALL JUMPERS WITH THE ENGINE PANEL TERMINAL NUMBER.
 - 5) PROVIDE MECHANICAL GROUND LUGS FASTENED TO BACK PANEL AND GROUNDED TO ENGINE-GENERATOR. GROUND ALL SHIELD DRAIN WIRES TO LUGS AT BACK PANEL ONLY.
 - 6) PROVIDE WIRING HARNESSSES FOR CONNECTION TO GENERATOR AND TO ENGINE. INSTALL WIRES IN LIQUID TIGHT FLEX OR FLEXIBLE PLASTIC WIRE LOOM AND PROVIDE SERVICE LOOPS IN ACCORDANCE WITH SPECIFICATIONS.

- FIELD INSTALLATION NOTES:**
- 1) PERFORM ALL FIELD WIRING IN ACCORDANCE WITH SPECIFICATIONS. LABEL BOTH ENDS OF ALL FIELD WIRING WITH THE ENGINE PANEL TERMINAL NUMBER.
 - 2) ON SHIELDED CONDUCTORS GROUND ALL SHIELD DRAIN WIRES AT ENGINE J-BOX ONLY. CLIP DRAIN WIRES AT OPPOSITE ENDS.

ISSUED FOR
ENGINE
GENERATOR
PROCUREMENT



ALASKA ENERGY AUTHORITY

PROJECT: KWETHLUK M&I 2025 IMPROVEMENTS

TITLE: GEN#3 ENGINE WIRING J-BOX LAYOUT & BILL OF MATERIALS

	DRAWN BY: JTD	SCALE: AS NOTED
	DESIGNED BY: CWV/BCG	DATE: 4/25/25
	FILE NAME: KWT 2025 M&I	SHEET: E6.5
	PROJECT NUMBER:	

P.O. 111405, Anchorage, AK 99511 (907)349-0100

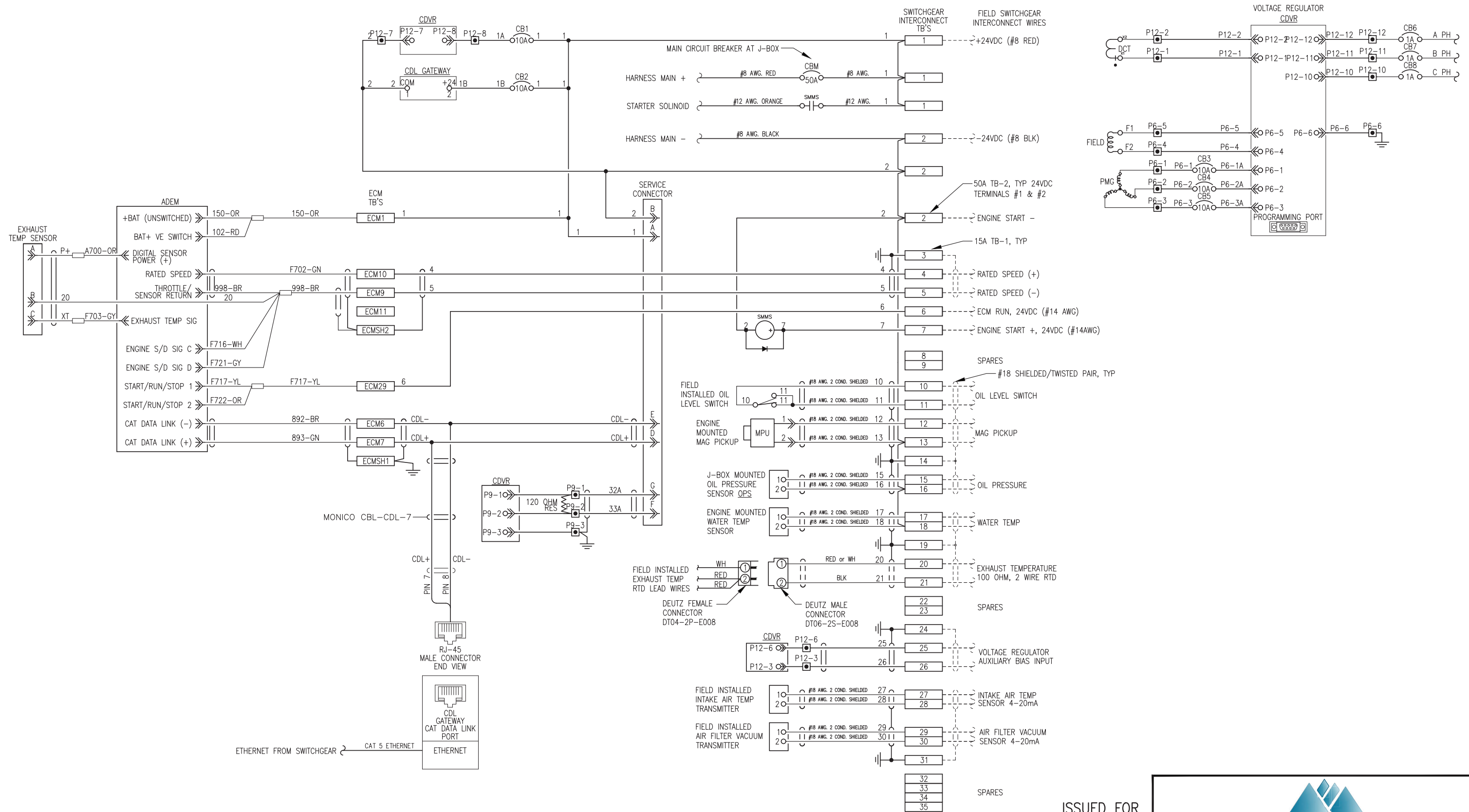

ISSUED FOR
ENGINE
GENERATOR
PROCUREMENT



ALASKA ENERGY AUTHORITY

PROJECT: KWETHLUK M&I 2025 IMPROVEMENTS		
TITLE: GEN#3 ENGINE WIRING J-BOX WIRING DIAGRAM & SWITCHGEAR INTERCONNECT		
DRAWN BY: JTD	SCALE: AS NOTED	
DESIGNED BY: CWV/BCG	DATE: 4/25/25	
FILE NAME: KWT 2025 M&I	SHEET:	
P.O. 111405, Anchorage, AK 99511 (907)349-0100	PROJECT NUMBER:	E6.6

